



MICRO GROW

GREENHOUSE SYSTEMS, INC

26111 YNEZ RD., SUITE C-4, TEMECULA, CA 92591 PHONE (909)-695-7280 FAX (909)-695-7282

Rev. 1.2 01/29/02

Growstat Series
Weatherstat

WEATHERSTAT

Greenhouse Wind and Rain Control

Description

The Weatherstat is a precise, microprocessor based control panel. It is designed to deliver a pilot duty, 24 VAC signal when high wind speeds are sensed. The unit features a rain output that will provide a 24 VAC output during periods of precipitation. A temperature sensor will indicate the outdoor temperature and retain the highest and lowest temperature reading experienced in the previous 24 hour time period.

Uses:

The primary use of the Weatherstat is to provide an override signal to close greenhouse roof vents in the event of high winds and rain. Additionally, outdoor shading systems and retractable roof greenhouses may be overridden during periods of wind and rain. Disabling of outdoor irrigation systems may also be controlled.

Wind Operation:

A precision sensor is mounted at the highest point of the greenhouse. This sensor will take a sample of the wind speed at this location. When a wind speed that is greater than the setting entered into the control panel is realized, the wind output is energized. Variable time delays are user selectable to release the output after the wind subsides.

Rain Operation:

Located along with the wind sensor is a plated rain sensing conductive grid. When this grid gets wet, the rain output is triggered on the Weatherstat. As soon as the rain output is triggered, small heating elements will be activated directly under the grid to attempt to dry off the grid. When the grid is fully dry, the output will then be disabled.

Outdoor Temperature:

The purpose of this sensor is to provide a reading of the outdoor temperature on the system. The current reading, as well as the highest and lowest reading during the previous 24 hour period can be displayed. There are no control functions associated with the outdoor temperature reading. It is a visual indicator only.

Electrical Power Requirements:

The Weatherstat is powered by a 24 VAC (not included). Use a sufficiently sized transformer to handle not only the control panel, but also any additional connected relay loads. We recommend at least a 40 VA industrial grade transformer. Micro Grow has these transformers in stock.

System Override Connections:

On some control systems, (such as the Procom and Growcom Systems) the Weatherstat may be directly connected to the main ventilation or environmental control system. Generally, these type of systems can take a direct 24 VAC signal from a remote source such as the Weatherstat. Most systems however will require one or more control relays to interrupt the normal operations of the vent or shade system during an override period. Consult Micro Grow for details on your particular system.

Operation:

After all connections have been made, apply 24 VAC to the circuit board. The display should read out the following items in a repetitive manner:

Wind Speed; Wind Output Status; Rain Output Status; Outdoor Temperature; Time of Day

Make sure that all sensor readings are correct. If there are any sensor readings that appear to be in error, please double check the connection diagram and wiring.

To Set Wind Speed:

Depress the **SET** switch once. The set wind speed MPH will be indicated on the display. You may then use the **VALUE** switch to raise or lower the setting. Release the momentary switch once the desired value appears in the display. This value is now locked in. You may return to the operation mode by moving the **RUN** switch into the upper position, or proceed with the other settings.

To Set Rain Sensitivity:

Depress the **SET** switch repeatedly until the rain sensitivity is shown on the display. This is indicated by the words **LO** or **HI**. Releasing the switch will lock in the sensitivity choice.

To Set 24 Hour Clock:

Depress the **SET** switch repeatedly until the display indicates the time of day. The first digit (hour) will be flashing. Use the **VALUE** switch to set the desired hour. Depressing the **SET** switch again will advance to the minutes. Set the minutes in the same manner using the **VALUE** switch. One additional depression of the **SET** switch will indicate **A** (AM) or **P** (PM).

Calibration:

Calibration should not be required, however if desired, the temperature and the wind speed can both be calibrated here. Depress the **SET** switch repeatedly until the display indicates the outdoor temperature. Use the **VALUE** switch to enter a new reading. Repeat as needed for wind speed.

High and Low Temperature Memory:

To display the highest and lowest outdoor temperatures realized in the previous 24 hours of operation, depress the **SET** switch repetitively until the word **HIGH** appears in the display. This will automatically be followed by the highest temperature realized. Depressing the **SET** switch once more will bring up the **LO** indicator, followed by the lowest temperature realized during the previous 24 hour period.

Custom DIP Switch Settings:

A DIP switch is located on the circuit board. The purpose of this switch is to allow for delay period changes in regards to the wind speed output on and off times. A switch is also provided to display the temperature readout in Celsius or Fahrenheit.

WEATHERSTAT TO PROCOM OVERRIDES

24 VAC
TRANSFORMER
40 VA MINIMUM
RATING

OUTPUT NOTE:
THE OUTPUTS OF THE WEATHERSTAT
MAY CONNECT DIRECTLY TO THE OVERRIDE
INPUTS OF A CONTROL SYSTEM CAPABLE OF
ACCEPTING A 24 VAC SIGNAL. IF OTHER
SWITCHING IS DESIRED, THE OUTPUTS MAY
BE CONNECTED TO THE COILS OF CONTROL
RELAYS TO INTERRUPT THE AUTOMATIC OPERATION
OF VENTS, RETRACTABLE ROOFS, ETC.

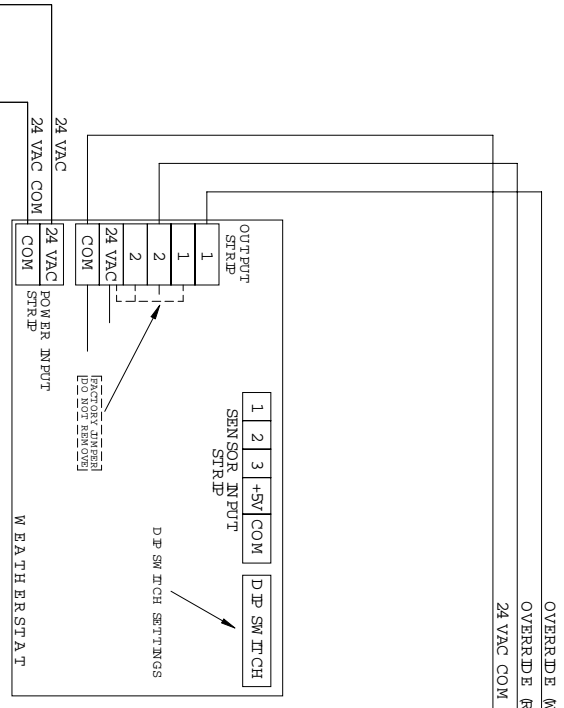

OVERRIDE (WIND)
OVERRIDE (RAIN)
24 VAC COM

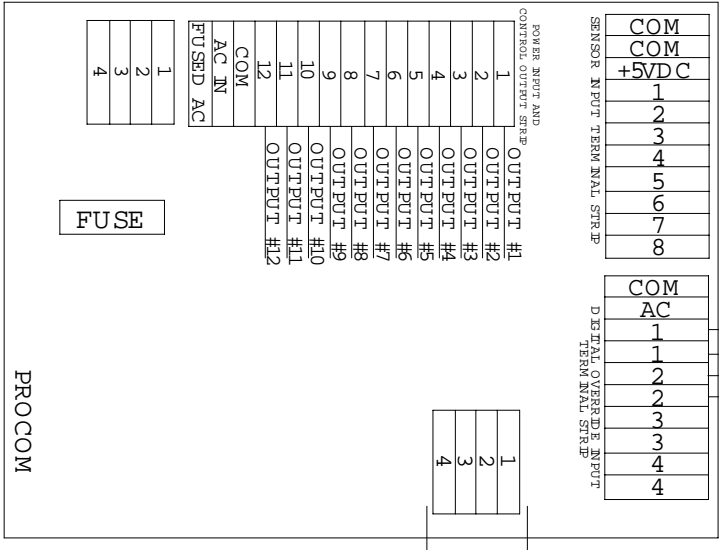

PLEASE REFER TO THE WEATHERSTAT MANUAL FOR MORE INFORMATION.

M I C R O G R O W G R E E N H O U S E S Y S T E M S , I N C .
26111 Ynez Road, Site C-4
Temecula, CA 92591
Phone 909.296.3340 Fax 909.296.3350

Project WEATHERSTAT TO PROCOM OVERRIDES			
Drawn by GH	Date 02/07/02	Distributor N/A	Order D N/A

VENTMATE PLUS DIRECT OVERRIDE CONNECTIONS

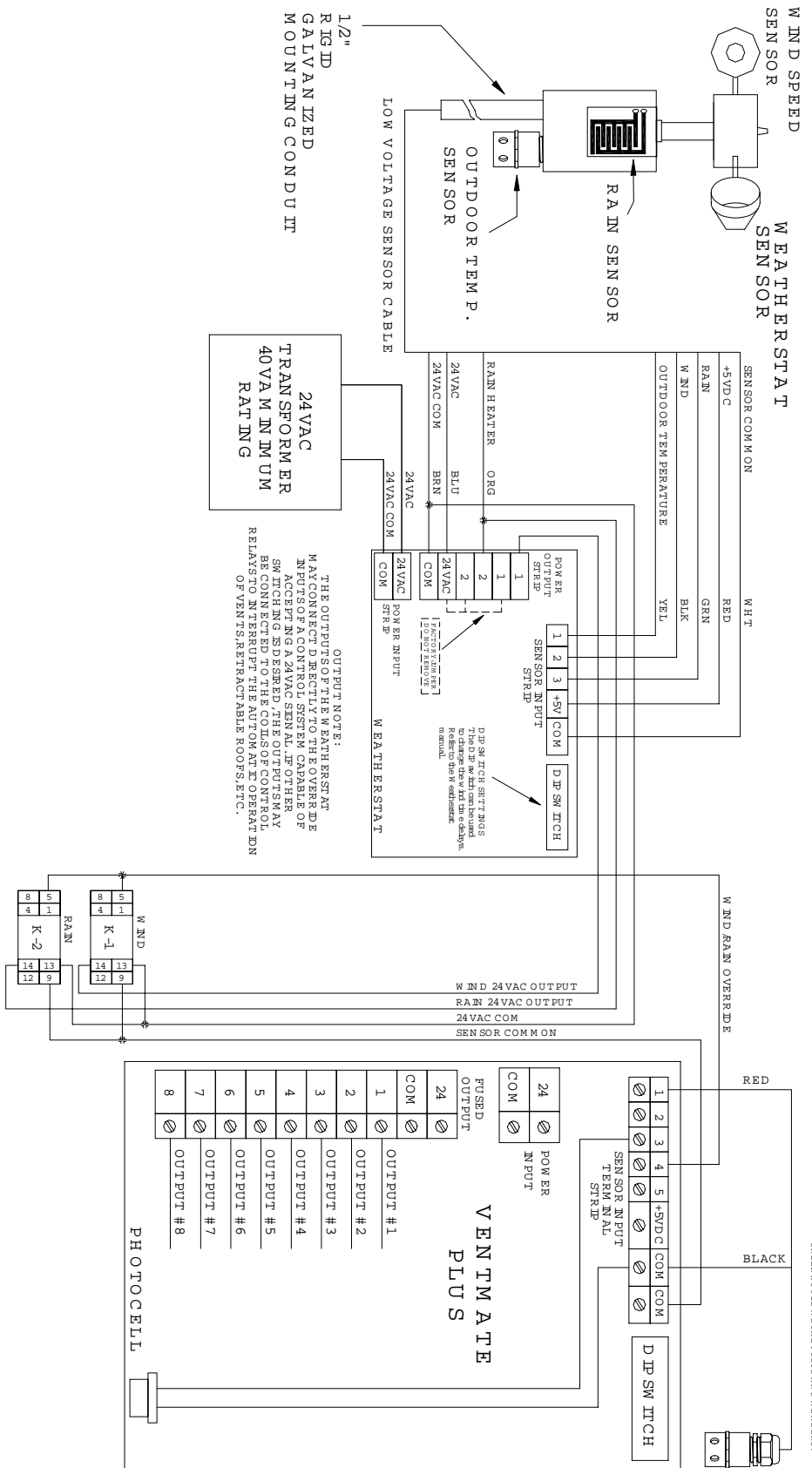

MICRO GROW GREENHOUSE SYSTEMS, INC.
26111 Ynez Road, Suite C-4
Temecula, CA 92591
Phone 909.296.3340 Fax 909.296.3350

Project VENTMATE PLUS DIRECT OVERRIDE CONNECTIONS			
Drawn by GH	Date 02/07/02	Distributor NA	Order D NA

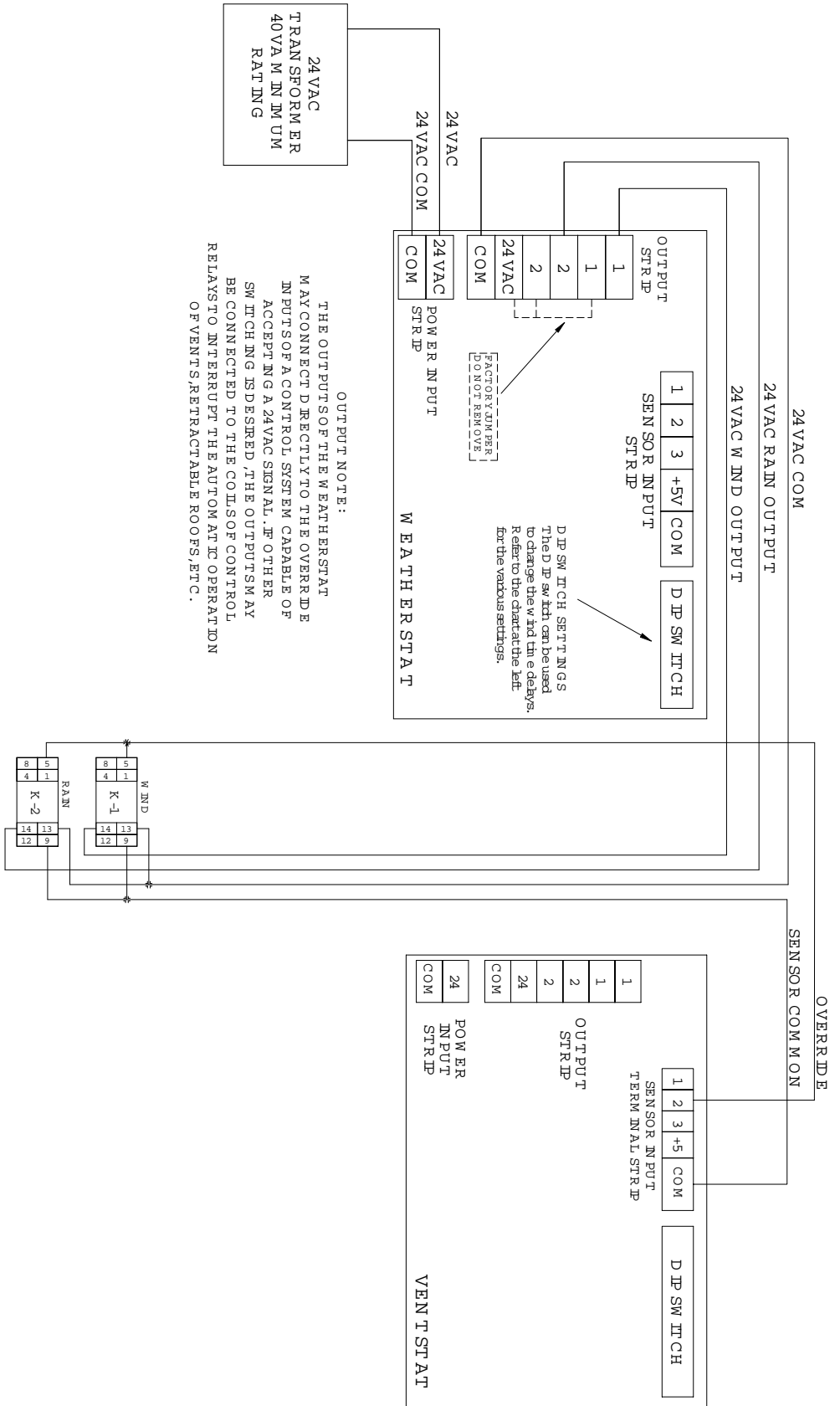

OUTPUT NOTE:

THE OUTPUTS OF THE WEATHERSTAT MAY CONNECT DIRECTLY TO THE OVERRIDE INPUTS OF A CONTROL SYSTEM CAPABLE OF ACCEPTING A 24VAC SIGNAL. OTHER SWITCHING IS DESIRED, THE OUTPUTS MAY BE CONNECTED TO THE COLLISION CONTROL RELAYS TO INTERRUPT THE AUTOMATIC OPERATION OF EVENTS, RETRACTABLE ROOFS, ETC.

WEATHERSTAT TO VENTSTAT
DIRECT OVERRIDE CONNECTIONS

1/4" UNLESS OTHERWISE SPECIFIED

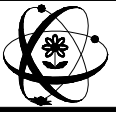

MICRO GROW GREENHOUSE SYSTEMS, INC.
26111 Ynez Road, Suite C-4
Temecula, CA 92591
Phone 909.296.3340 Fax 909.296.3350

Project WEATHERSTAT TO VENTSTAT OVERRIDE CONNECTIONS			
Drawn by GH	Date 02/08/02	Distributor N/A	Order ID N/A

LIMITED WARRANTY

Micro Grow Greenhouse Systems, Inc. warrants that all of the products Micro Grow Greenhouse Systems, Inc. manufactures are free from defects at the time of shipment by Micro Grow Greenhouse Systems, Inc. This warranty covers defects in workmanship and materials. No warranty is extended on any parts, materials, or components manufactured by others and purchased by Micro Grow Greenhouse Systems, Inc., and any warranty on these materials is limited to the warranty supplied by the original manufacturer or supplier of said products only. This warranty excludes any and all damages caused by installation by unqualified individuals, damage by misuse or neglect, shipment damage, alterations to original manufacturing, and improper installation or use for any reason than intended by manufacturer. This warranty may not be altered in any manner except with the written authorization of one of the officers or owners of Micro Grow Greenhouse Systems, Inc. The only and sole liability of Micro Grow Greenhouse Systems, Inc. under this warranty is limited to repairing, replacing or the issuance of credit for any products returned to Micro Grow Greenhouse Systems, Inc., during the warranty period of twelve (12) months from date of shipment. This warranty is specifically conditioned upon Micro Grow Greenhouse Systems, Inc. being notified in writing promptly upon discovery of any product defects by the buyer or end user. The product must then be returned prepaid to Micro Grow Greenhouse Systems, Inc. within the twelve month warranty period for inspection by Micro Grow Greenhouse Systems, Inc. Upon inspection of said product, Micro Grow Greenhouse Systems, Inc. will notify buyer or end user of its findings. At Micro Grow Greenhouse Systems, Inc. sole discretion, the product will be replaced, repaired or a credit will be issued for the original sale price of the product, provided that damage has not occurred due to misuse, neglect, improper use or installation as outlined above, shipping damages or accident.

MICRO GROW GREENHOUSE SYSTEMS, INC. SHALL NOT BE LIABLE FOR ANY DAMAGES BEYOND THE ACTUAL ORIGINAL COST OF THEIR PRODUCT EITHER DIRECTLY OR INDIRECTLY ARISING FROM DEFECTIVE PRODUCTS OR WORKMANSHIP.